

12 SB 100 (12V 100Ah)

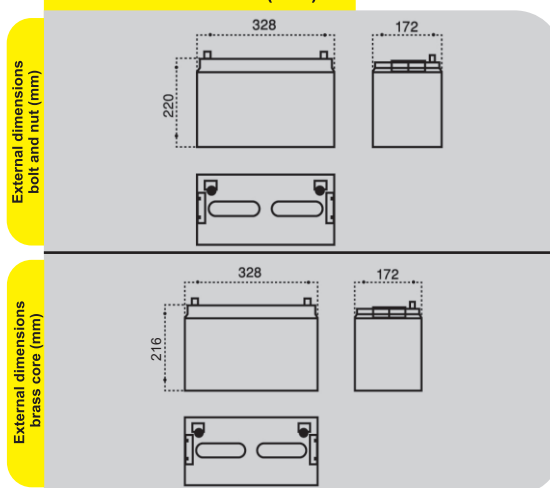

Outer Dimensions (mm)



Specifications

Nominal Voltage		12 V	12 V
Rated Capacity (10 Hour Rate)		100 Ah	100 Ah
Dimensions	Total Height	242 mm	222 mm
	Height	220 mm	216 mm
	Length	328 mm	328 mm
	Width	172 mm	172 mm
Terminal		F2	F1
Container Material		ABS (UL94-HB/V0)	
Weight Approx (±2.5%)		31 Kg	31 Kg

Terminal Type brass core (mm) (F1)

Terminal Type bolt and nut (mm) (F2)

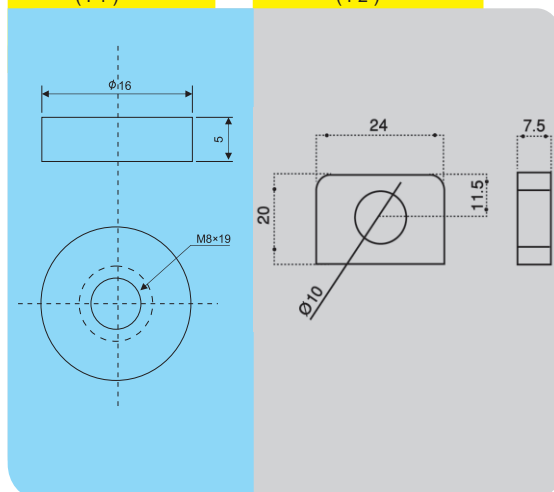

Characteristics

Capacity 25°C (77°F)	10 hour-rate	100 Ah
	3 hour-rate	75 Ah
	1 hour-rate	55 Ah
Internal Resistance	Full Charge Battery at 25°C (77°F)	4.5 mΩ
Capacity Affected by Temperature (10 Hour Rate)	35°C	102 Ah
	25°C	100 Ah
	0°C	85 Ah
	-10°C	75 Ah
Self-Discharge at 25°C (77°F)	Capacity After The 3 Month of Storage	91 %
	Capacity After The 6 Month of Storage	82 %
	Capacity After The 12 Month of Storage	64 %
Charge Constant Voltage	Cycle	Voltage 2.40-2.45 / Cell
	Float	Voltage 2.23-2.28 / Cell

Discharge Curves 25°C (77°F)

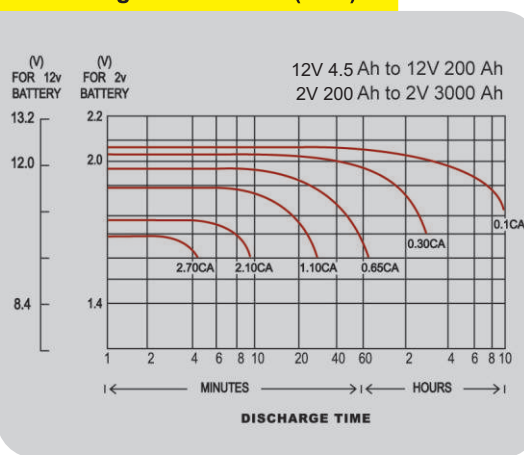

Discharge and Final Voltage Table According to IEC60896-21 Standard

Discharge time	0.25 h	1 h	3 h	5 h	8 h	10 h
Final voltage	1.60 VPC	1.60 VPC	1.70 VPC	1.73 VPC	1.75 VPC	1.80 VPC

Constant Current (A) Discharge Table at 25°C (77°F)

Amount of Current (A)	Discharge Time						
	1 h	2 h	3 h	5 h	8 h	10 h	20 h
	55	31.8	25	16	11	10	5.4