

12 FT 155 (12V 155Ah)

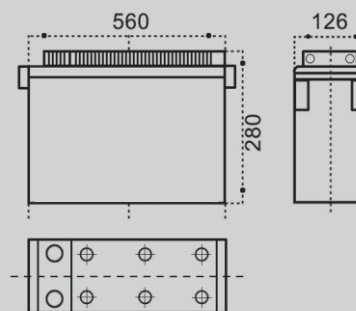

Outer Dimensions (mm)



Specifications

Nominal Voltage		12 V
Rated Capacity (10 Hour Rate)		155 Ah
Dimensions	Total Height	280 mm
	Height	280 mm
	Length	560 mm
	Width	126 mm
Container Material		ABS (UL94-HB/V0)
Weight Approx (±2.5%)		54 Kg

Terminal Type (mm)

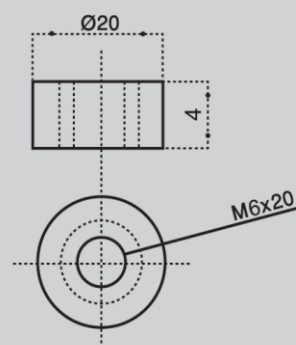

Characteristics

Capacity 25°C (77°F)	10 hour-rate	155 Ah
	3 hour-rate 1 hour-rate	114 Ah 84 Ah
Internal Resistance	Full Charge Battery at 25°C (77°F)	4.5 mΩ
Capacity Affected by Temperature (10 Hour Rate)	35°C	158 Ah
	25°C	155 Ah
	0°C	131 Ah
	-10°C	116 Ah
Self-Discharge at 25°C (77°F)	Capacity After The 3 Month of Storage	91 %
	Capacity After The 6 Month of Storage	82 %
	Capacity After The 12 Month of Storage	64 %
Charge Constant Voltage	Cycle	Voltage 2.40-2.45 / Cell
	Float	Voltage 2.23-2.25 / Cell

Discharge Curves 25°C (77°F)

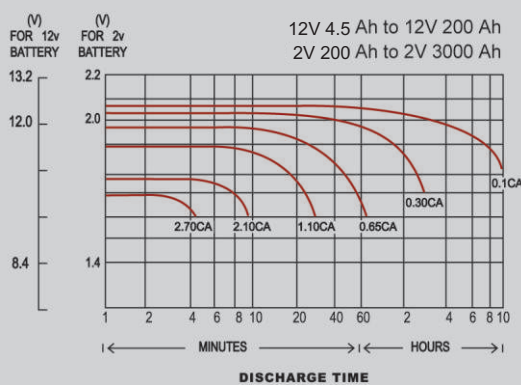

Discharge and Final Voltage Table According to IEC60896-21 Standard

Discharge time	0.25 h	1 h	3 h	5 h	8 h	10 h
Final voltage	1.60 VPC	1.60 VPC	1.70 VPC	1.73 VPC	1.75 VPC	1.80 VPC

Constant Current (A) Discharge Table at 25°C (77°F)

Amount of Current (A)	Discharge Time						
	1 h	2 h	3 h	5 h	8 h	10 h	20 h
	84	59	38	25	18.7	15.5	8.1